

18. CONTROL SYSTEM ANALYSIS

Topics:

Objectives:

18.1 INTRODUCTION

18.2 CONTROL SYSTEMS

- Control systems use some output state of a system and a desired state to make control decisions.

- In general we use negative feedback systems because,
 - they typically become more stable
 - they become less sensitive to variation in component values
 - it makes systems more immune to noise

- Consider the system below, and how it is enhanced by the addition of a control system.

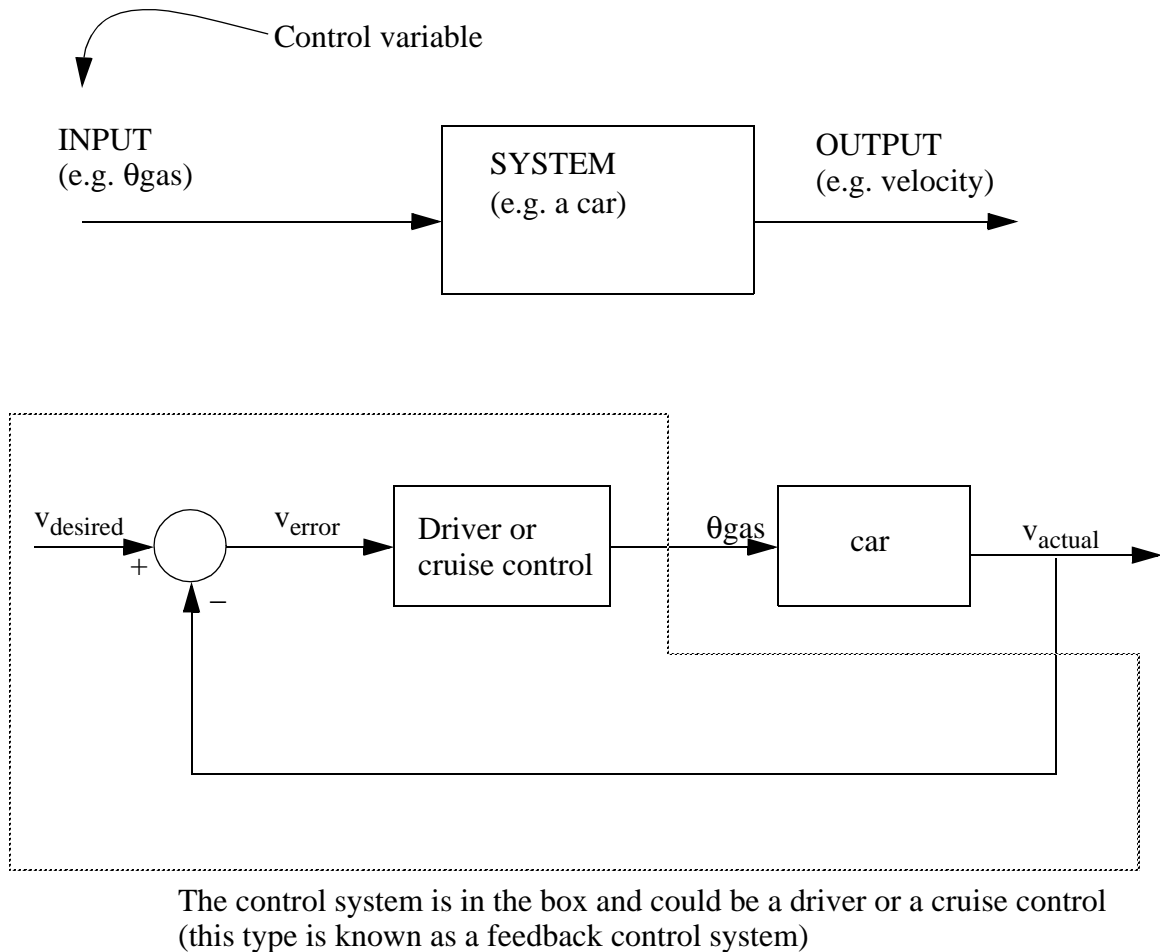

Figure 18.1 An example of a feedback controller

Human rules to control car (also like expert system/fuzzy logic):

1. If v_{error} is not zero, and has been positive/negative for a while, increase/decrease θ_{gas}
2. If v_{error} is very big/small increase/decrease θ_{gas}
3. If v_{error} is near zero, keep θ_{gas} the same
4. If v_{error} suddenly becomes bigger/smaller, then increase/decrease θ_{gas} .
5. etc.

Figure 18.2 Rules for a feedback controller

- Some of the things we do naturally (like the rules above) can be done with mathematics

18.2.1 PID Control Systems

- The basic equation for a PID controller is shown below. This function will try to compensate for error in a controlled system (the difference between desired and actual output values).

$$u = K_c e + K_i \int e dt + K_d \left(\frac{de}{dt} \right)$$

Figure 18.3 The PID control equation

- The figure below shows a basic PID controller in block diagram form.

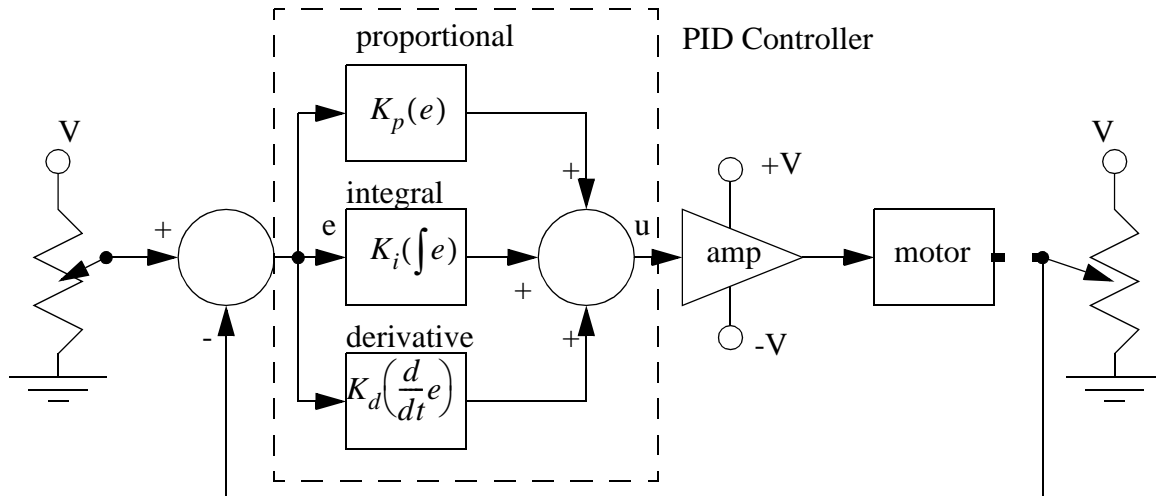
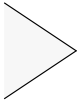

Figure 18.4 A block diagram of a feedback controller

e.g.

$$\theta_{gas} = K_c v_{error} + K_i \int v_{error} dt + K_d \left(\frac{dv_{error}}{dt} \right)$$

Rules 2 & 3
(general difference) Rule 1
(Long term error) Rule 4
(Immediate error)

K_c
 K_i
 K_d

 Relative weights of components

This is a PID Controller

Proportional
 Integral
 Derivative

For a PI Controller

$$\theta_{gas} = K_c v_{error} + K_i \int v_{error} dt$$

For a P Controller

$$\theta_{gas} = K_c v_{error}$$

For a PD Controller

$$\theta_{gas} = K_c v_{error} + K_d \left(\frac{dv_{error}}{dt} \right)$$

- The PID controller is the most common controller on the market.

18.2.2 Analysis of PID Controlled Systems With Laplace Transforms

1. We can rewrite the control equation as a ratio of output to input.

$$\theta_{gas} = K_c v_{error} + K_i \int v_{error} dt + K_d \left(\frac{dv_{error}}{dt} \right)$$

$$\frac{\theta_{gas}}{v_{error}} = K_c + K_i \int dt + K_d \left(\frac{d}{dt} \right)$$



Then do a Laplace transform

$$\frac{d}{dt} \rightarrow s$$

$$\frac{dx}{dt} \rightarrow sx$$

$$\int dt = \frac{1}{s}$$

$$\int x dt = \frac{x}{s}$$

$$L \left[\frac{\theta_{gas}}{v_{error}} \right] = K_c + \frac{K_i}{s} + K_d s$$

The transfer function

2. We can also develop a transfer function for the car.

$$F = A\theta_{gas} = 10\theta_{gas}$$

$$\frac{F}{\theta_{gas}} = 10$$

Transfer function for engine and transmission. (Laplace transform would be the same as initial value.)

$$F = Ma = M\frac{d^2x}{dt^2} = M\frac{dv}{dt}$$

$$\frac{F}{v} = M\frac{d}{dt}$$

$$L\left[\frac{v}{F}\right] = \frac{1}{Ms}$$

Transfer function for acceleration of car mass

3. We want to draw the system model for the car.

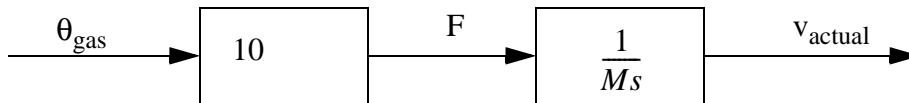

- The ‘system model’ is shown above.
- If θ_{gas} is specified directly, this is called ‘open loop control’. This is not desirable, but much simpler.
- The two blocks above can be replaced with a single one.

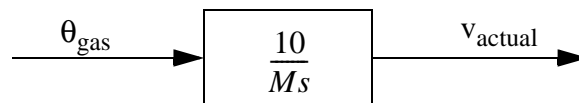

4. If we have an objective speed, and an actual speed, the difference is the 'system error'

$$v_{error} = v_{desired} - v_{actual}$$

↖ 'set-point' - desired system operating point

5. Finally, knowing the error is v_{error} , and we can control θ_{gas} (the control variable), we can select a control system.



$$L\left[\frac{\theta_{gas}}{v_{error}}\right] = K_c + \frac{K_i}{s} + K_d s$$

*The coefficients can be calculated using classical techniques, but they are more commonly approximated by trial and error.

6. For all the components we can now draw a 'block diagram'

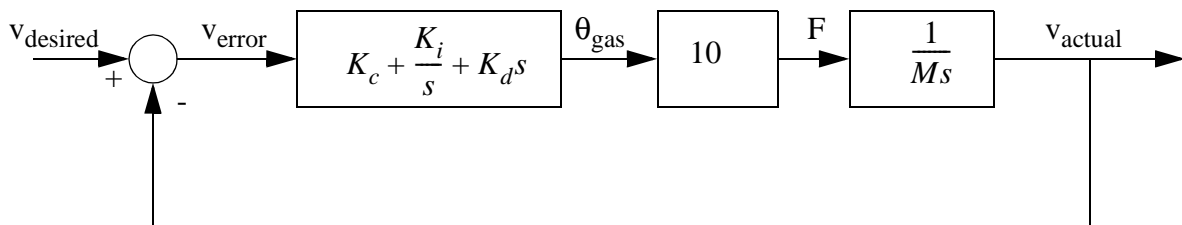



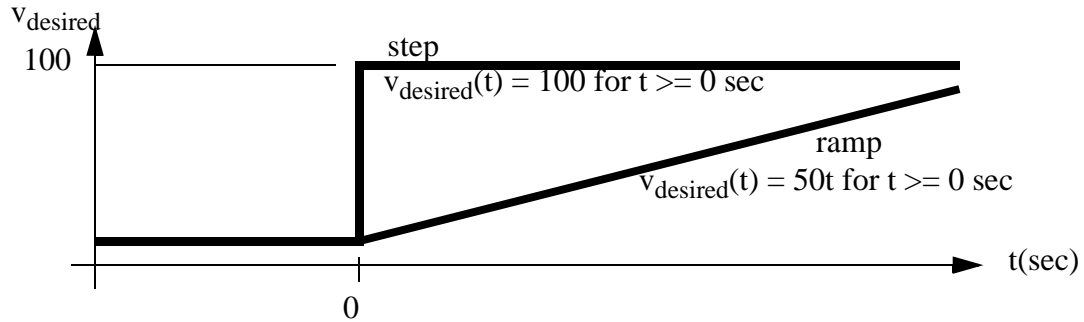

• A 'negative feedback loop that is the fundamental part of this 'closed loop control system'

18.2.3 Finding The System Response To An Input

- Even though the transfer function uses the Laplace 's', it is still a ratio of input to output.
- Find an input in terms of the Laplace 's'



	Input type	Time function	Laplace function
	STEP	$f(t) = Au(t)$	$f(s) = \frac{A}{s}$
	RAMP	$f(t) = Atu(t)$	$f(s) = \frac{A}{s^2}$
	SINUSOID	$f(t) = A \sin(\omega t)u(t)$	$f(s) = \frac{A\omega^2}{s^2 + \omega^2}$
	PULSE	$f(t) = A(u(t) - u(t - t_1))$	$f(s) =$
	etc.....		

Therefore to continue the car example, lets assume the input below,

$$v_{desired}(t) = 100 \quad t \geq 0 \text{ sec}$$

$$v_{desired}(s) = L[v_{desired}(t)] = \frac{100}{s}$$

Next, lets use the input, and transfer function to find the output of the system.

$$v_{actual} = \left(\frac{v_{actual}}{v_{desired}} \right) v_{desired}$$

$$v_{actual} = \left(\frac{s^2(K_d) + s(K_c) + K_i}{s^2\left(\frac{M}{10} + K_d\right) + s(K_c) + K_i} \right) \left(\frac{100}{s} \right)$$

To go further, some numbers will be selected for the values.

$$K_d = 10000$$

$$K_c = 10000$$

$$K_i = 1000$$

$$M = 1000$$

$$v_{actual} = \left(\frac{s^2(10000) + s(10000) + 1000}{s^2(10100) + s(10000) + 1000} \right) \left(\frac{100}{s} \right)$$

At this point we have the output function, but not in terms of time yet. To do this we break up the function into partial fractions, and then find inverse Laplace transforms for each.

$$v_{actual} = 10^2 \left(\frac{s^2 + s + 0.1}{s(s^2(1.01) + s + 0.1)} \right)$$

Aside: We must find the roots of the equation, before we can continue with the partial fraction expansion.

recall the quadratic formula,

$$ax^2 + bx + c = 0 \quad x = \frac{-b \pm \sqrt{b^2 - 4ac}}{2a}$$

$$\therefore x = \frac{-1 \pm \sqrt{1^2 - 4(1.01)(0.1)}}{2(1.01)} = -0.113, -0.877$$

$$v_{actual} = \frac{10^2}{1.01} \left(\frac{s^2 + s + 0.1}{s(s + 0.113)s + 0.877} \right)$$

$$v_{actual} = \frac{A}{s} + \frac{B}{s + 0.114} + \frac{C}{s + 0.795}$$

$$A = \lim_{s \rightarrow 0} \left[s \left(\frac{10^2}{1.01} \left(\frac{s^2 + s + 0.1}{s(s + 0.113)(s + 0.877)} \right) \right) \right] = \frac{10^2}{1.01} \left(\frac{0.1}{(0.113)(0.877)} \right)$$

$$\therefore A = 99.9$$

$$B = \lim_{s \rightarrow -0.113} \left[\left(\frac{10^2}{1.01} \left(\frac{s^2 + s + 0.1}{s(s + 0.113)(s + 0.877)} \right) \right) (s + 0.113) \right]$$

$$\therefore B = \left(\frac{10^2}{1.01} \left(\frac{(-0.113)^2 + (-0.113) + 0.1}{(-0.113)(-0.113 + 0.877)} \right) \right) = 0.264$$

$$C = \lim_{s \rightarrow -0.877} \left[\left(\frac{10^2}{1.01} \left(\frac{s^2 + s + 0.1}{s(s + 0.113)(s + 0.877)} \right) \right) (s + 0.877) \right]$$

$$\therefore C = \left(\frac{10^2}{1.01} \left(\frac{(-0.877)^2 + (-0.877) + 0.1}{(-0.877)(-0.877 + 0.113)} \right) \right) = -1.16$$

$$v_{actual} = \frac{99.9}{s} + \frac{0.264}{s + 0.113} - \frac{1.16}{s + 0.877}$$

Next we use a list of forward/inverse transforms to replace the terms in the partial fraction expansion.

$f(t)$	$f(s)$
A	$\frac{A}{s}$
At	$\frac{A}{s^2}$
$Ae^{-\alpha t}$	$\frac{A}{s + \alpha}$
$A \sin(\omega t)$	$\frac{A\omega}{s^2 + \omega^2}$
$e^{-\xi\omega_n t} \sin(\omega_n t \sqrt{1 - \xi^2})$	$\frac{\omega_n \sqrt{1 - \xi^2}}{s^2 + 2\xi\omega_n s + \omega_n^2} \quad \text{for } (\xi < 1)$

etc.

To finish the problem, we simply convert each term of the partial fraction back to the time domain.

$$v_{actual} = \frac{99.9}{s} + \frac{0.264}{s + 0.113} - \frac{1.16}{s + 0.877}$$

$$v_{actual} = 99.9 + 0.264e^{-0.113t} - 1.16e^{-0.877t}$$

18.2.4 Controller Transfer Functions

- The table below is for typical control system types,

Type	Transfer Function
Proportional (P)	$G_c = K$
Proportional-Integral (PI)	$G_c = K\left(1 + \frac{1}{\tau s}\right)$
Proportional-Derivative (PD)	$G_c = K(1 + \tau s)$
Proportional-Integral-Derivative (PID)	$G_c = K\left(1 + \frac{1}{\tau s} + \tau s\right)$
Lead	$G_c = K\left(\frac{1 + \alpha\tau s}{1 + \tau s}\right) \quad \alpha > 1$
Lag	$G_c = K\left(\frac{1 + \tau s}{1 + \alpha\tau s}\right) \quad \alpha > 1$
Lead-Lag	$G_c = K\left[\left(\frac{1 + \tau_1 s}{1 + \alpha\tau_1 s}\right)\left(\frac{1 + \alpha\tau_2 s}{1 + \tau_2 s}\right)\right] \quad \begin{array}{l} \alpha > 1 \\ \tau_1 > \tau_2 \end{array}$

18.3 ROOT-LOCUS PLOTS

- Consider the basic transform tables. A superficial examination will show that the denominator (bottom terms) are the main factor in determining the final form of the solution. To explore this further, consider that the roots of the denominator directly impact the partial fraction expansion and the following inverse Laplace transfer.

- When designing a controller with variable parameters (typically variable gain), we need to determine if any of the adjustable gains will lead to an unstable system.

- Root locus plots allow us to determine instabilities (poles on the right hand side of the plane), overdamped systems (negative real roots) and oscillations (complex roots).

- Note: this procedure can take some time to do, but the results are very important when designing a control system.

- Consider the example below,

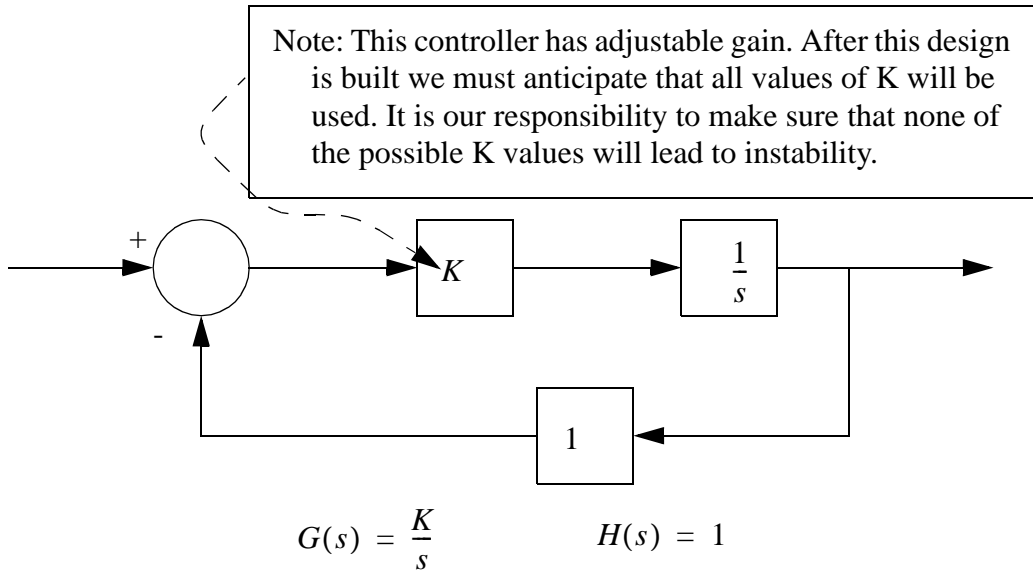

First, we must develop a transfer function for the entire control system.

$$G_S(s) = \frac{G(s)}{1 + G(s)H(s)} = \frac{\left(\frac{K}{s}\right)}{1 + \left(\frac{K}{s}\right)(1)} = \frac{K}{s + K}$$

Next, we use the characteristic equation of the denominator to find the roots as the value of K varies. These can then be plotted on a complex plane. Note: the value of gain 'K' is normally found from 0 to +infinity.

$s + K = 0$	K	root
	0	
	1	
	2	
	3	
	etc..	

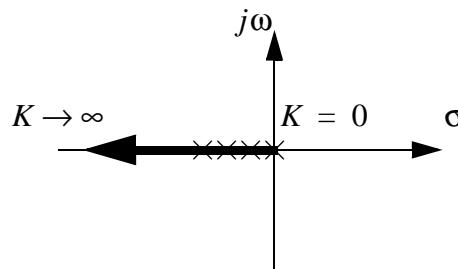

Note: because all of the roots for all values of K are real negative this system will always be stable, and it will always tend to have a damped response. The large the value of K, the more stable the system becomes.

- Consider the previous example, the transfer function for the whole system was found, but then only the denominator was used to determine stability. So in general we do not need to find the transfer function for the whole system.

Consider the general form for a negative feedback system.

$$G_s(s) = \frac{G(s)}{1 + G(s)H(s)}$$

Note: two assumptions that are not often clearly stated are that we are assuming that the control system is a negative feedback controller, and that when not given the feedback gain is 1.

The system response is a function of the denominator, and it's roots.

$$1 + G(s)H(s) = 0$$

It is typical, (especially in textbook problems) to be given only $G(s)$ or $G(s)H(s)$.

The transfer function values will often be supplied in a pole zero form.

$$G(s)H(s) = \frac{K(s + z_0)(s + z_1)\dots(s + z_m)}{(s + p_0)(s + p_1)\dots(s + p_n)}$$

- Consider the example,

Given the system elements (you should assume negative feedback),

$$G(s) = \frac{K}{s^2 + 3s + 2} \quad H(s) = 1$$

First, find the characteristic equation, and an equation for the roots,

$$1 + \left(\frac{K}{s^2 + 3s + 2} \right) (1) = 0$$

$$s^2 + 3s + 2 + K = 0$$

$$\text{roots} = \frac{-3 \pm \sqrt{9 - 4(2 + K)}}{2} = -1.5 \pm \frac{\sqrt{1 - 4K}}{2}$$

Next, find values for the roots and plot the values,

K	root
0	0
1	-1
2	-2
3	-3

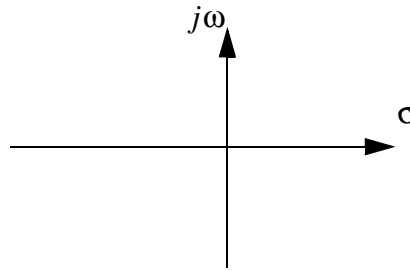

*****CALCULATE AND PUT IN NUMBERS

18.3.1 Approximate Plotting Techniques

- The basic procedure for creating root locus plots is,

1. write the characteristic equation. This includes writing the poles and zeros of the

equation.

$$1 + G(s)H(s) = 1 + K \frac{(s + z_1)(s + z_2) \dots (s + z_m)}{(s + p_1)(s + p_2) \dots (s + p_n)} = 0$$

2. count the number of poles and zeros. The difference (n-m) will indicate how many root loci lines end at infinity (used later).
3. plot the root loci that lie on the real axis. Points will be on a root locus line if they have an odd number of poles and zeros to the right. Draw these lines in.
4. determine the asymptotes for the loci that go to infinity using the formula below. Next, determine where the asymptotes intersect the real axis using the second formula. Finally, draw the asymptotes on the graph.

$$\beta(k) = \frac{\pm 180^\circ(2k + 1)}{n - m} \quad k \in [0, n - m - 1]$$

$$\sigma = \frac{(p_1 + p_2 + \dots + p_n)(z_1 + z_2 + \dots + z_m)}{n - m}$$

5. the breakaway and breakin points are found next. Breakaway points exist between two poles on the real axis. Breakin points exist between zeros. to calculate these the following polynomial must be solved. The resulting roots are the breakin/breakout points.

$$A = (s + p_1)(s + p_2) \dots (s + p_n) \quad B = (s + z_1)(s + z_2) \dots (s + z_m)$$

$$\left(\frac{d}{ds}A\right)B - A\left(\frac{d}{ds}B\right) = 0$$

6. Find the points where the loci lines intersect the imaginary axis. To do this substitute the phasor for the laplace variable, and solve for the frequencies. Plot the asymptotic curves to pass through the imaginary axis at this point.

$$1 + K \frac{(j\omega + z_1)(j\omega + z_2) \dots (j\omega + z_m)}{(j\omega + p_1)(j\omega + p_2) \dots (j\omega + p_n)} = 0$$

- Consider the example in the previous section,

Given the system elements (you should assume negative feedback),

$$G(s) = \frac{K}{s^2 + 3s + 2} \quad H(s) = 1$$

Step 1: (put equation in standard form)

$$1 + G(s)H(s) = 1 + \left(\frac{K}{s^2 + 3s + 2}\right)(1) = 1 + K\frac{1}{(s + 1)(s + 2)}$$

Step 2: (find loci ending at infinity)

$$m = 0 \quad n = 2 \quad (\text{from the poles and zeros of the previous step})$$

$$n - m = 2 \quad (\text{loci end at infinity})$$

Step 3: (plot roots)

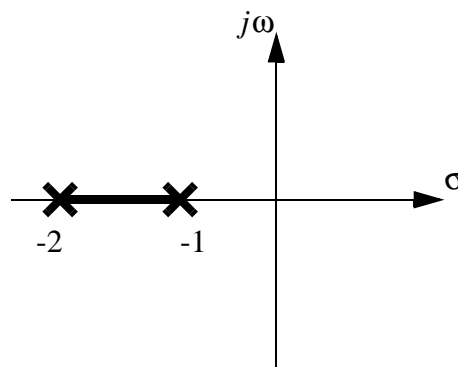

Step 4: (find asymptotes angles and real axis intersection)

$$\beta(k) = \frac{180^\circ(2k + 1)}{2} \quad k \in I[0, 1]$$

$$\beta(0) = \frac{180^\circ(2(0) + 1)}{2} = 90^\circ$$

$$\beta(1) = \frac{180^\circ(2(1) + 1)}{2} = 270^\circ$$

$$\sigma = \frac{(0)(-1 - 2)}{2} = 0$$

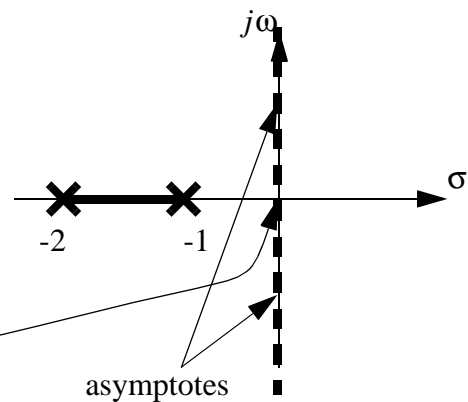

Step 5: (find the breakout points for the roots)

$$A = 1 \quad B = s^2 + 3s + 2$$

$$\frac{d}{ds}A = 0 \quad \frac{d}{ds}B = 2s + 3$$

$$A\left(\frac{d}{ds}B\right) - B\left(\frac{d}{ds}A\right) = 0$$

$$1(2s + 3) - (s^2 + 3s + 2)(0) = 0$$

$$2s + 3 = 0$$

$$s = -1.5$$

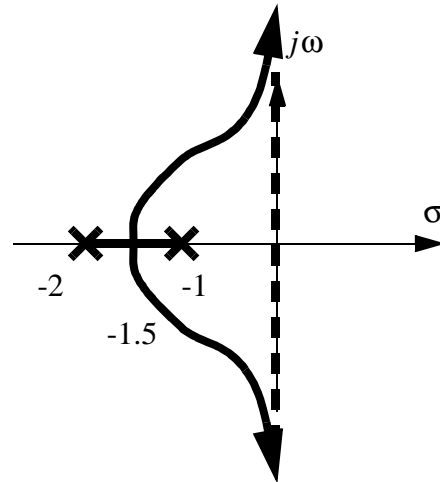

Note: because the loci do not intersect the imaginary axis, we know the system will be stable, so step 6 is not necessary, but we it will be done for illustrative purposes.

Step 6: (find the imaginary intercepts)

$$1 + G(s)H(s) = 0$$

$$1 + K \frac{1}{s^2 + 3s + 2} = 0$$

$$s^2 + 3s + 2 + K = 0$$

$$(j\omega)^2 + 3(j\omega) + 2 + K = 0$$

$$-\omega^2 + 3j\omega + 2 + K = 0$$

$$\omega^2 + \omega(-3j) + (-2 - K) = 0$$

$$\omega = \frac{3j \pm \sqrt{(-3j)^2 - 4(-2 - K)}}{2} = \frac{3j \pm \sqrt{-9 + 8 + 4K}}{2} = \frac{3j \pm \sqrt{4K - 1}}{2}$$

In this case the frequency has an imaginary value. This means that there will be no frequency that will intercept the imaginary axis.

- Plot the root locus diagram for the function below,

$$G(s)H(s) = \frac{K(s+5)}{s(s^2+4s+8)}$$

18.4 DESIGN OF CONTINUOUS CONTROLLERS

18.5 SUMMARY

•

18.6 PRACTICE PROBLEMS

3. Given the transfer function below, and the input 'x(s)', find the output 'y(t)' as a function of time.

$$\frac{y(s)}{x(s)} = \frac{5}{s+2} \qquad x(t) = 5 \quad t \geq 0 \text{ sec}$$

8. Draw a detailed root locus diagram for the transfer function below. Be careful to specify angles of departure, ranges for breakout/breakin points, and gains and frequency at stability limits.

$$G(s) = \frac{2K(s+0.5)(s^2+2s+2)}{s^3(s+1)(s+2)}$$

10. Draw the root locus diagram for the transfer function below,

$$G(s) = \frac{K(s+4)^2}{s^2(s+1)}$$

11. Draw the root locus diagram for the transfer function below,

$$G(s) = \frac{K(s+1)(s+2)}{s^3}$$

12. The block diagram below is for a motor position control system. The system has a proportional controller with a variable gain K.

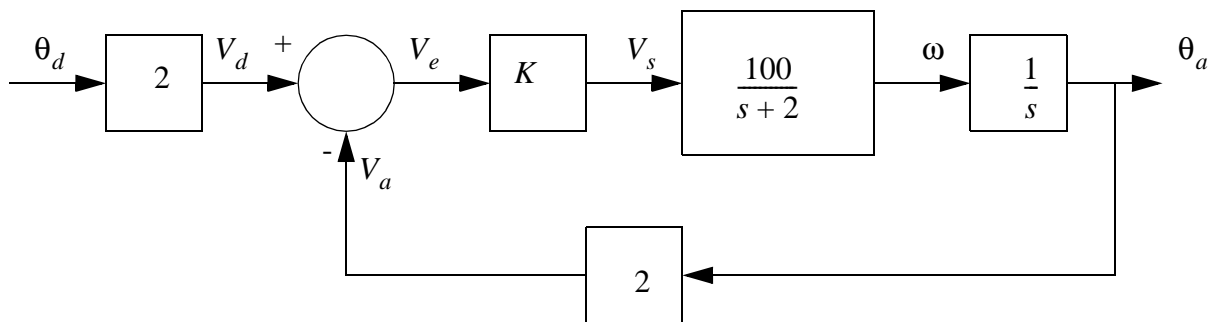

a) Simplify the block diagram to a single transfer function.

ans. $\frac{200K}{s^2 + 2s + 200K}$

b) Draw the Root-Locus diagram for the system (as K varies). Use either the approximate or exact techniques.

ans.

$$\text{roots} = \frac{-2 \pm \sqrt{4 - 4(200K)}}{2} = -1 \pm \sqrt{1 - 200K}$$

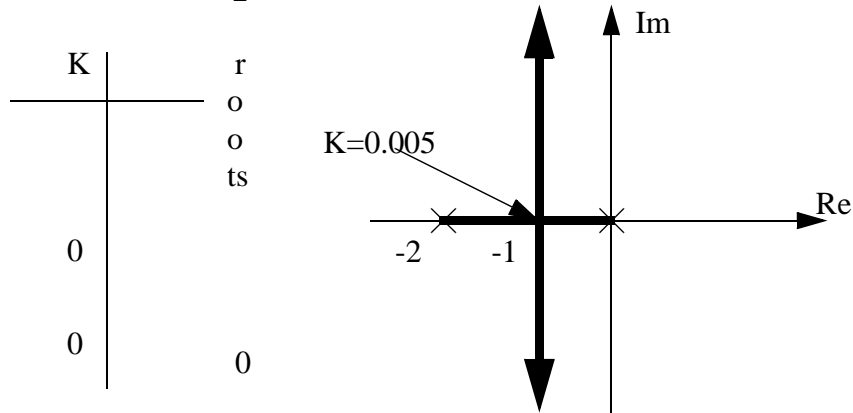

c) Select a K value that will result in an overall damping coefficient of 1. State if the Root-Locus diagram shows that the system is stable for the chosen K.

(ans. $s^2 + 2s + 200K = s^2 + 2\zeta\omega_n s + \omega_n^2 \quad \therefore \omega_n = 1 \quad \therefore K = 0.005$)

From the root locus graph this value is critically stable.

13. Draw a Bode Plot for either one of the two transfer functions below.

$$\frac{(s + 1)(s + 1000)}{(s + 100)^2} \quad \text{OR} \quad \frac{5}{s^2}$$

15. Given the system transfer function below.

$$\frac{\theta_o}{\theta_d} = \frac{20K}{s^2 + s + 20K}$$

- Draw the root locus diagram and state what values of K are acceptable.
- Select a gain value for K that has either a damping factor of 0.707 or a natural frequency of 3 rad/sec.
- Given a gain of K=10 find the steady state response to an input step of 1 rad.
- Given a gain of K=10 find the response of the system as

17. The equation below describes a dynamic system. The input is 'F' and the output is 'V'. It has the initial values specified. The following questions ask you to find the system response to a

unit step input using various techniques.

$$V'' + 10V' + 20V = -20F \quad V(0) = 1 \quad V'(0) = 2$$

- Find the response using Laplace transforms.
- Find the response using the homogenous and particular solutions.
- Put the equation in state variable form, and solve it using your calculator. Sketch the result accurately below.

18. A feedback control system is shown below. The system incorporates a PID controller. The closed loop transfer function is given.

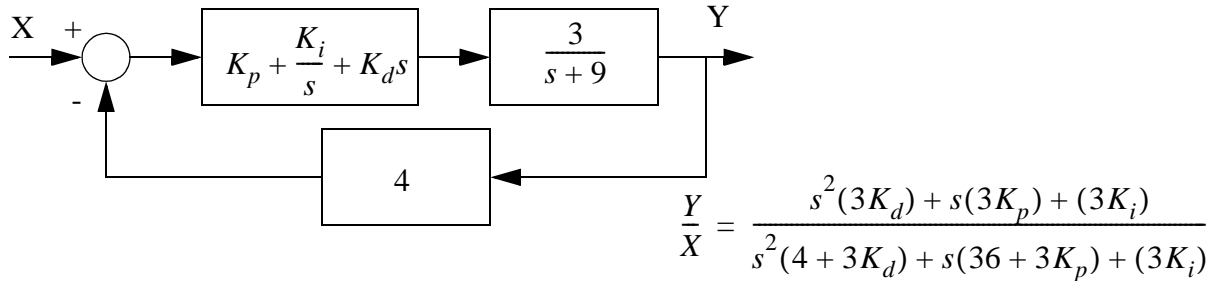

- Verify the close loop controller function given.
- Draw a root locus plot for the controller if $K_p=1$ and $K_i=1$. Identify any values of K_d that would leave the system unstable.
- Draw a Bode plot for the feedback system if $K_d=K_p=K_i=1$.
- Select controller values that will result in a natural frequency of 2 rad/sec and damping coefficient of 0.5. Verify that the controller will be stable.
- For the parameters found in the last step find the initial and final values.
- If the values of $K_d=1$ and $K_i=K_d=0$, find the response to a ramp input as a function of time.

19. The following system is a feedback controller for an elevator. It uses a desired height 'd' provided by a user, and the actual height of the elevator 'h'. The difference between these two is called the error 'e'. The PID controller will examine the value 'e' and then control the speed of the lift motor with a control voltage 'c'. The elevator and controller are described with transfer functions, as shown below. all of these equations can be combined into a single system transfer

equation as shown.

$$e = d - h \quad \text{error}$$

$$\frac{c}{e} = K_p + \frac{K_i}{s} + K_d s = \frac{2s + 1 + s^2}{s} \quad \text{PID controller} \qquad \frac{h}{c} = \frac{10}{s^2 + s} \quad \text{elevator}$$

combine the transfer functions

$$\left(\frac{c}{e}\right)\left(\frac{h}{c}\right) = \frac{h}{e} = \frac{2s + 1 + s^2}{s} \frac{10}{s^2 + s} = \frac{(s + 1)^2}{s} \frac{10}{s(s + 1)} = \frac{10(s + 1)}{s^2}$$

$$\frac{h}{d - h} = \frac{10(s + 1)}{s^2} \qquad \text{eliminate 'e'}$$

$$h = \left(\frac{10(s + 1)}{s^2}\right)(d - h)$$

$$h\left(1 + \frac{10(s + 1)}{s^2}\right) = \left(\frac{10(s + 1)}{s^2}\right)(d)$$

$$\frac{h}{d} = \left(\frac{\frac{10(s + 1)}{s^2}}{1 + \frac{10(s + 1)}{s^2}}\right) = \frac{10s + 10}{s^2 + 10s + 10} \qquad \text{system transfer function}$$

- Find the response of the final equation to a step input. The system starts at rest on the ground floor, and the input (desired height) changes to 20 as a step input.
- Write find the damping coefficient and natural frequency of the results in part a).
- verify the solution using the initial and final value theorems.

$$\text{(ans. a)} \quad \frac{h}{d} = \frac{10s + 10}{s^2 + 10s + 10} \quad d(t) = 20u(t) \quad d(s) = \frac{20}{s}$$

$$h = \left(\frac{10s + 10}{s^2 + 10s + 10} \right) \frac{20}{s} = \frac{A}{s} + \frac{B}{s + 5 - 3.873j} + \frac{C}{s + 5 + 3.873j}$$

$$A = \lim_{s \rightarrow 0} \left(\frac{200s + 200}{s^2 + 10s + 10} \right) = 20$$

$$B = \lim_{s \rightarrow -5 + 3.873j} \left(\frac{200s + 200}{s(s + 5 + 3.873j)} \right) = -2.5 - 22.6j$$

$$C = -2.5 + 22.6j$$

$$h(t) = 20 + L^{-1} \left[\frac{-2.5 - 22.6j}{s + 5 - 3.873j} + \frac{-2.5 + 22.6j}{s + 5 + 3.873j} \right] \quad |A| = \sqrt{2.5^2 + 22.6^2} = 22.73$$

$$\theta = 4.602$$

$$\alpha = 5$$

$$\beta = 3.873$$

$$h(t) = 20 + 2(22.73)e^{-5t} \cos(3.873t + 4.602)$$

$$\begin{aligned} \text{b)} \quad -5 &= -\omega_n \zeta & \zeta &= \frac{5}{\omega_n} \\ 3.873 &= \sqrt{1 - \zeta^2} \omega_n = \sqrt{1 - \frac{25}{\omega_n^2}} \omega_n \\ 15 &= \left(1 - \frac{25}{\omega_n^2} \right) \omega_n^2 = \omega_n^2 - 25 & \omega_n &= \sqrt{35} = 5.916 \\ & & \zeta &= \frac{5}{\sqrt{35}} = 0.845 \end{aligned}$$

$$\text{c)} \quad h(0) = \lim_{s \rightarrow \infty} \left[s \left(\frac{10s + 10}{s^2 + 10s + 10} \right) \frac{20}{s} \right] = \lim_{s \rightarrow \infty} \left[\left(\frac{10s}{s^2} \right) 20 \right] = 0$$

$$h(\infty) = \lim_{s \rightarrow 0} \left[s \left(\frac{10s + 10}{s^2 + 10s + 10} \right) \frac{20}{s} \right] = \frac{(10)20}{10} = 20$$

18.7 PRACTICE PROBLEM SOLUTIONS

18.8 ASSIGNMENT PROBLEMS

1. a) The block diagram below is for an angular positioning system. The setpoint is a desired angle, which is converted to a desired voltage. This is compared to a feedback voltage from a potentiometer. A PID controller is used to generate an output voltage to drive a DC motor. Simplify the block diagram.

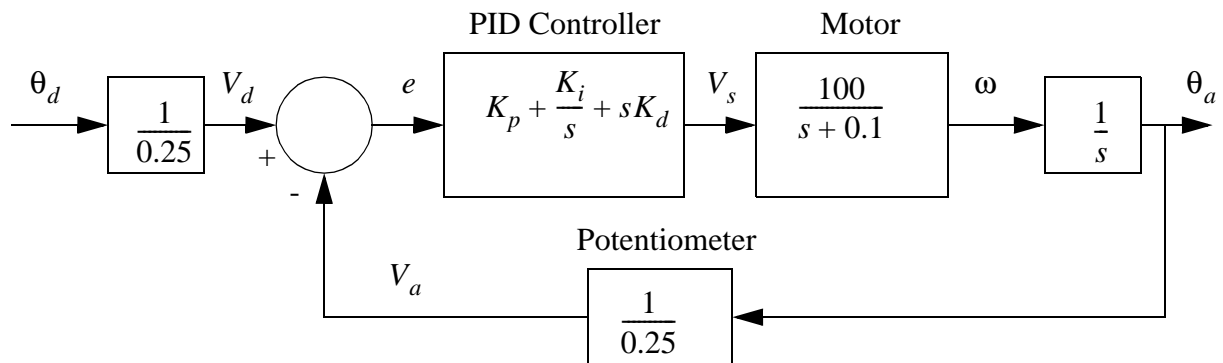

- b) Given the transfer function below, select values for K_p , K_i and K_d that will result in a second order response that has a damping coefficient of 0.125 and a natural frequency of 10rad/s. (Hint: eliminate K_i).

$$\frac{\theta_a}{\theta_d} = \frac{s^2(400K_d) + s(400K_p) + (400K_i)}{s^3 + s^2(0.1 + 400K_d) + s(400K_p) + (400K_i)}$$

- c) The function below has a step input of magnitude 1.0. Find the output as a function of time using numerical methods. Give the results in a table OR graph.

$$\frac{\theta_a}{\theta_d} = \frac{s(0.9) + (4)}{s^2 + 2.5s + 100}$$

- d) The function below has a step input of magnitude 1. Find the output as a function of time by integrating the differential equation (i.e., using the homogeneous and particular solutions).

$$\frac{\theta_a}{\theta_d} = \frac{s(0.9) + (4)}{s^2 + 2.5s + 100}$$

- e) The function below has a step input of magnitude 1. Find the output as a function of time using Laplace transforms.

$$\frac{\theta_a}{\theta_d} = \frac{s(0.9) + (4)}{s^2 + 2.5s + 100}$$

- f) Given the transfer function below; a) apply a phasor/Fourier transform and express the gain and phase angle as a function of frequency, b) calculate a set of values and present them in a table, c) use the values calculated in step b) to develop a frequency response plot on semi-log paper, d) draw a straight line approximation of the Bode plot on semi-log paper.

$$\frac{\theta_a}{\theta_d} = \frac{s(0.9) + (4)}{s^2 + s + 4}$$

2. Select a controller transfer function, G_c , that will reduce the system to a first order system with a time constant of 0.5s, as shown below.

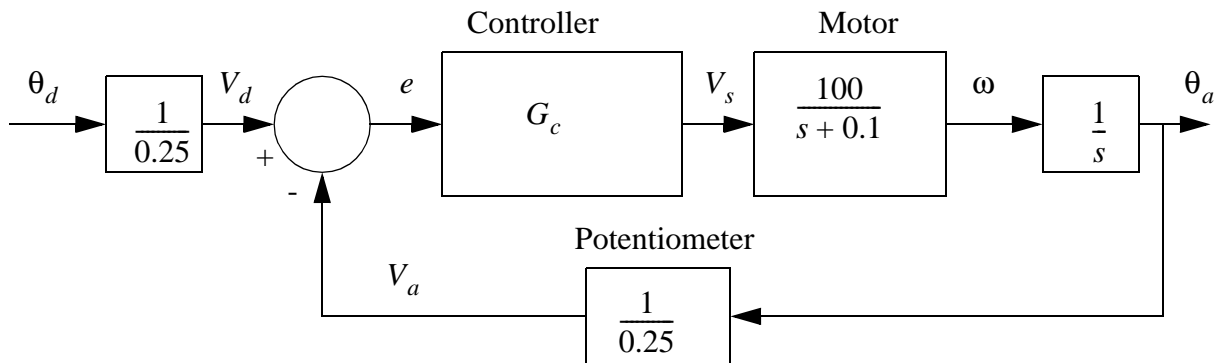

desired transfer function $\frac{\theta_a}{\theta_d} = \frac{1}{s + 2}$